

# TC 154

MIGHTY MITE  
TUBE CHECKER

# S E N C O R E



## SENCORE SERVICE MANUAL

426 S. WESTGATE DRIVE, ADDISON, ILLINOIS 60101

# SAFETY PRECAUTIONS

When testing electronic equipment, there is always a danger present. Unexpected high voltages can be present at unusual locations in defective equipment. The technician should become familiar with the device that he is working on and observe the following precautions.

1. An isolation transformer should always be used on equipment having the chassis tied to one side of the AC power line.
2. When making test lead connections to high voltage points, remove the power, if this cannot be done, be sure to avoid contact with other equipment or metal objects. Place one hand in your pocket as a safety precaution and stand on an insulated floor to reduce the possibility of shock.
3. Discharge filter capacitors before connecting test leads to them. Capacitors can store a charge that could be dangerous to the technician.
4. Be sure your equipment is in good order. Broken or frayed test leads can be extremely dangerous and can expose the technician to dangerous potentials.
5. Remove the test leads immediately after the test has been completed to reduce the possibility of shock.
6. Do not work alone when working on hazardous circuits. Always have another person close by in case of accident. Remember, even a minor shock can be the cause of a more serious accident, such as falling against the equipment, or coming in contact with higher voltages.

# TABLE OF CONTENTS

PAGE

SAFETY PRECAUTIONS . . . . .	2
DESCRIPTION . . . . .	3
SPECIFICATIONS . . . . .	3
Tests the Mighty Mite will make . . . . .	3
OPERATION . . . . .	4
Acquainting yourself with the Mighty Mite . . . . .	4
Operating the Mighty Mite . . . . .	4
Additional Tests and Functions of the Mighty Mite . . . . .	5
Setting up the Mighty Mite for new tubes. . . . .	6
Example of setting up the Mighty Mite. . . . .	7
MAINTENANCE . . . . .	8
Disassembly Instructions. . . . .	8
Emission Calibration . . . . .	8
Circuit description . . . . .	9
Trouble chart. . . . .	10
Parts List. . . . .	11
Service and Warranty. . . . .	12
FIGURES	
Fig. 1 - 9QL Tube basing . . . . .	7
Fig. 2 - Cal Module Schematic. . . . .	8
Fig. 3 - P. C. Board layout . . . . .	9
Fig. 4 - Schematic diagram . . . . .	11

# INSTRUCTION MANUAL FOR THE SENCORE TC154 MIGHTY MITE VI TUBE TESTER.

## DESCRIPTION

The new Sencore Mighty Mite VI represents a unique breakthrough in tube testers. The Mighty Mite VI is completely solid state using the FET in a balanced bridge for an instant on checker. This new outstanding feature means that no time is wasted waiting for the checker to warm up and stabilize before accurate testing can begin. The new Mighty Mite is ready as soon as it is turned on. A full load cathode current check, high sensitivity grid leakage check, and the famous Sencore Stethoscopic shorts test make this the ideal checker for service work and the man on the go. Check the features of the Mighty Mite below:

- \* Full load cathode current check to pick out the weak tubes other checkers miss.
- \* 100 megohm grid leakage sensitivity to find the tough dog tubes fast.
- \* Stethoscopic shorts test of 300K to pick out true shorts in the tube.
- \* Burnout proof meter, even if a shorted tube is tested backwards.
- \* FET balanced bridge circuitry for instant on action and greater accuracy.
- \* All steel case for maximum protection and good looks for the life of the checker.

## SPECIFICATIONS

Cathode Emission Test: Full load current drawn through tube up to 120 mA. Max applied voltage, 40 VAC RMS.

Grid Leakage Test: Good area, infinity to 200 megohms, ? area, 200 to 100 megohms and the Bad area 100 megohms or less.

Shorts Test: 300,000 ohms or less will cause shorts light to come on. Maximum applied voltage, 40 VAC RMS.

Power: 105 to 125 VAC, 50/60 Hertz at 32 watts maximum.

## TESTS THE MIGHTY MITE WILL MAKE

Cathode Emission: The Mighty Mite tests all tubes at near their full rated cathode current level for the best emission check. This is very important as many testers do not test at this high level of current and can pass many tubes as good that will not work satisfactorily in the circuit. This test is very important on high power tubes such as rectifiers, horizontal and sound output tubes.

Grid Leakage Test: Grid leakage or grid emission in a tube can upset many circuits, including the AGC, Chroma, Video, Sync, and others. Grid currents as low as one microamp can change the bias in these circuits causing many headaches. The Mighty Mite detects grid current as low as one-half a microamp or 100 megohms to pick out these trouble making tubes that are often missed by other tube checkers. As soon as the tube is warm enough to indicate cathode emission, the grid leakage test can be preformed.

**Shorts Test:** The Sencore "Stethoscopic" shorts test picks out true shorts between elements in the tube of 300,000 ohms or less. Above this value, the shorts light may flicker indicating a high resistance short in the tube. The applied voltage is kept below the 50 volt maximum to prevent damage to frame grid tubes and nuvistors. This prevents the Mighty Mite from damaging tubes and introducing a short in the tube that was not there before.

## OPERATION

### ACQUAINTING YOURSELF WITH THE MIGHTY MITE

The Mighty Mite is composed of four setup controls and four push button switches. The four controls marked A - FILAMENT, B - LOAD, C - SETUP, and D - SETUP are set according to the information in the setup chart. The tube is inserted into one of the thirteen sockets numbered from one to thirteen as indicated in the setup chart. The Grid Cap lead, located in the lower corner of the front panel, is placed on tubes having a grid or plate cap. The desired function is selected by depressing the button corresponding with the test desired, Emission, Shorts, or Grid Leakage. The tests can be made in any order without damage to the checker, even if the tube under test is shorted.

### OPERATING THE MIGHTY MITE

1. Plug the AC line cord into a 105 to 125 VAC, 50 to 60 Hertz receptacle.
2. Locate the tube in the setup chart in the cover. The tubes are listed numerically and alphabetically. Looking to the right of the tube number, note the setup information for the controls A, B, C, D, and socket number. Some tubes have more than one listing indicating the tube has more than one section to be tested. Each section of a multiple section tube is tested separately.
3. Set the controls A, B, C, and D as indicated in the setup chart and insert the tube into the socket listed. Where more than one setting is listed, make the tests on each setting. The shorts test need be made only once on most tubes.
4. Depress the SHORTS button and check the METER ZERO adjust for a 0 indication on the meter. Then rotate the "D" switch through all its positions noting the SHORTS light. The light will glow if a short of 300,000 ohms or less is present. If the light does glow, be sure it glows on both elements. In some tubes, shorts exist that do not affect the operation of the tube are marked with an asterisk (\*) in the tube chart. If the SHORTS light glows on the marked points of the "D" switch, then no shorts that will affect the tube operation are present. If the SHORTS light glows on a point other than that marked in the setup book, then a short is present. Some tubes may show a short on only one pin of the tube. This is because the suppressor grid is tied to the cathode of the tube internally and may indicate a short on only one position of the "D" switch. If the short is present on two or more positions, than a short does exist. The tube should be rejected for shorts, except if they are indicated in the setup book. NOTE: A few tubes marked with an asterisk in the setup book and indicating as having a normal short may not show any shorts on the Mighty Mite. This is because some tube manufacturers use the spare base pins for extra internal connections, whereas other manufacturers of the same tube may not.
5. If the tube passes the SHORTS test, depress the EMISSION button and read the emission quality of the tube on the top scale of the meter. A tube indicating in the questionable area of the meter may or may not be rejected depending upon you and your customer.

6. If the tube reads in the GOOD area of the meter and passes the EMISSION test, depress the GRID LEAKAGE button and read the grid leakage of the tube on the bottom scale of the meter. This is a very important check and will show up a lot of troublesome tubes that may otherwise check good. If the meter is indicating in the GOOD area of the meter but slowly rising, wait a minute or so to see if the meter will finally climb into the BAD area of the meter. On heavy power tubes, such as a horizontal output tube, do not make a grid leakage check after an extended emission check. If the tube is left in the emission check position for several minutes, the grid will heat up and when switched to grid leakage will read higher than normal. Allow the tube to cool slightly before making the grid leakage check. You can expedite the grid leakage check by raising the filament switch for a few seconds. This is not the same overheating as was caused in the emission check, but will show up grid leakage. If the grid leakage indication climbs into the BAD area on the meter, reduce the filament voltage and see if the meter remains in the bad area. If it does so, then the tube will give trouble in the circuit and should be replaced. If the meter drops off rapidly back into the GOOD area, then the tube is good.

If the tube passes all the above tests, it can be considered good and should not be replaced. If the tube is in the questionable area on any test, it is up to you or your customer to decide if the tube should be replaced. Show your customer the action of the meter indication on the tube and explain what will happen. In this manner, the Mighty Mite becomes your customer convincer on new tube sales.

#### ADDITIONAL TESTS AND FUNCTIONS OF THE MIGHTY MITE

Tube Life Expectancy Test: If the meter needle climbs very slowly into the GOOD area or Questionable area of the meter on the Emission test, the life expectancy of the tube can be considered much less than if the meter indicated GOOD in a shorter period of time. Also, if the needle should climb into the GOOD area and then "fall off", life expectancy can be considered much less. We can not recommend that you replace these tubes. That decision is up to you or your customer.

Filament Warm-Up Time: When replacing a costly horizontal output tube in a television receiver, it is a good idea to not only check the horizontal oscillator for emission and other standard tests, but to also check the length of time it takes to warm up. If the horizontal oscillator tube is slower in warming up than the output tube, the output tube will draw heavy current and its life will be shortened considerably. Checking the warm up time of the oscillator tube and making sure that it is as fast or faster than the output tube can reduce the chance of a call back later for the same trouble and keep your customer's confidence high in your service ability.

Filament Voltage Sensitivity: Some tubes may check good on the emission test and pass the other test in the Mighty Mite, but may not always operate in the receiver. These tubes may have a filament sensitive cathode. That is, the emission from the tube will change with a change in filament voltage. These tubes can give trouble, especially in the newer series string receivers. A quick check on these tubes is to reduce the Filament switch "A" down one step and observe the emission reading on the meter of the Mighty Mite. A new tube will not change its emission reading at all when this step is preformed. A tube having a filament sensitive cathode will drop in emission reading when the filament switch is reduced one step. If the tube falls below the questionable area, the tube will give trouble in the circuit and should be replaced. If your in the home, be sure to show your customer the tube and how it checks on the Mighty Mite.

Rejuvenation: If you wish to rejuvenate a small tube, merely increase the filament voltage by setting switch "A" one setting higher for ten to fifteen seconds. This will super heat the cathode and boil out more emitting material from under the oxide coating. This is only a temporary measure as rejuvenation of a receiving tube will not last very long.

## SETTING UP THE MIGHTY MITE FOR NEW TUBES

New tubes can sometimes be a problem as they may not be listed in the setup chart. This can be the case, especially on new sets just introduced by the set manufacturers. With an understanding of the setup controls on the Mighty Mite, you can set up and check any new tube that is not listed in the setup chart.

**A FILAMENT Switch:** This switch selects the filament voltage applied to the tube under test from 1 (one) to over 50 volts. The twelve position switch selects a range of voltage and with the unique design of the filament transformer, the tube under test will load the transformer to obtain the correct voltage for testing. When setting up a new tube, simply set the A FILAMENT switch to the correct voltage or voltage range.

**B LOAD Switch:** This switch selects the proper AC voltage to be applied to the plate of the tube as well as the correct load resistor so that the tubes designed current can be set and the tube checked under full load. The current ranges for the settings of the B LOAD switch are as follows:

B LOAD switch	Cathode Current	B LOAD switch	Cathode Current
A	50 mA plus	F	2-7 mA
B	20-50 mA	G	.7-2 mA
C	15-30 mA	H	.5-.8 mA
D	10-16 mA	J	.5 mA or less
E	6-12 mA		

The current that the B LOAD switch is set to is the normal cathode current under normal bias conditions as listed in the tube manual. If a tube manual is not handy, then using Ohms law, compute the cathode current by the voltage drop across the cathode or plate load resistor in the circuit or from the schematic.

**C SETUP Switch:** The C SETUP switch is used to isolate extra connections inside of the tube such as two grid pins so that tests can be made. For example, Figure 1 shows a typical base diagram for a horizontal output tube, the 6JE6. Note that the control grid is connected to pins 2 and 6 on the tube base. Since the control grid must be picked up for the test, one of the connections must be isolated or opened up so that the test can be made. The following shows the pins isolated with the settings of the "C" SETUP switch.

C SETUP Switch	Pin isolated on Tube base	C SETUP Switch	Pin isolated on Tube base
1	1	7	6
2	2	8	7
3	3	9	8
4	4	10	9
5	5	11	10
6	No pins isolated, all feed through	12	No pins isolated, all feed through

In the example of Figure 1, if pin 2 were chosen to be isolated, the "C" switch would be set to position 2. If you choose to isolate pin 6, then the "C" switch would be set to 7 as indicated in the above chart. If there are no extra connections to be isolated in the tube, then the "C" switch will be set to position 6 so that all pins feed directly through.

**D SETUP Switch:** The "D" switch is used to pick up the control grid for the test on the tube. It was discovered many years ago, that approximately 97% of the electrons would go to the control grid when checking cathode emission so that this is now used as the pick-up element. In the example of Figure 1, the "D" switch would be set to one of the control grids that is not isolated. If pin 2 were to be isolated, then the "D" switch would be set to pick up pin 6. The following chart shows the positions of the "D" switch and the tube pins that are picked up:

D SWITCH settings	Pin on Tube base picked up	D SWITCH settings	Pin on Tube base picked up
A	1	G	7
B	2	H	8
C	3	J	9
D	4	K	10 and the grid cap lead
E	5	H-K	Not used as a pick-up
F	6		

The only exception to the above is on socket number 10 where pin 11 on the tube base is picked up with the first position of the "D" switch.

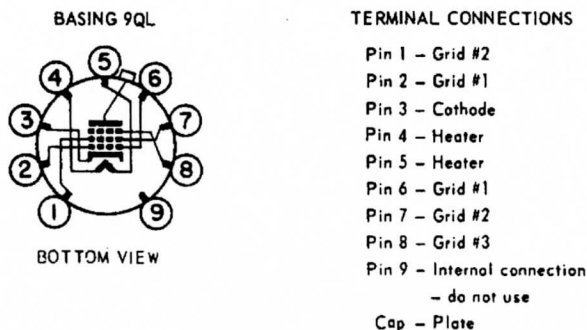

Figure 1. 9QL Tube basing

Sockets number 3 and 8 are wired identical except that socket number 8 has three pins not connected. This socket is used to isolate extra connections where more than two base pins are connected to the same element such as in the 1X2 high voltage rectifier. The seven pin sockets 4 and 7 are alike except that the filament pins on socket 4 are 3 and 4 while on socket 7 they are 1 and 7.

**SOCKET SETUP:** The sockets on the Mighty Mite have the filament pins prewired to eliminate the extra setup that is involved. The actual pin connections can be seen on the schematic diagram of the unit. Note that the two octal sockets have different filament connections. Socket number 1 is for filaments on pins 2 and 7 while socket number 2 is for filaments on pins 7 and 8. Sockets 3, 8, and 13 are for standard 9 pin base tubes. Sockets 3 and 8 have filaments on pins 4 and 5 while socket number 13 is for special Hi-Fi tubes with filaments on pins 1 and 2.

There are two novar sockets that are wired identical. Socket number 5 is for the standard novar based tubes while socket number 12 is for the magnoval based tubes. The pins on the magnoval based tubes are larger in diameter than the standard novar base and can damage the novar socket. All magnoval tubes are checked in socket number 12 to prevent damage to the regular novar socket number 5. When selecting the socket for a new tube, select the socket for the filament wiring as well as the socket the tube should fit into.

#### EXAMPLE OF SETTING UP THE MIGHTY MITE

Lets use for our example, the 6JE6 shown in Figure 1. This tube is a standard novar base tube with the control grid tied to two pins on the tube base.

**FIRST:** Determine the socket to use. In this case, the tube is a standard novar base tube so that socket number 5 will be used.

**SECOND:** Determine the filament voltage. In this case, it is the 6JE6 so that the filament switch "A" will be set to 6. The first set of numbers on the tube generally indicate the filament voltage of the tube. On foreign tubes, consult a substitution guide to find the filament voltage and characteristics that can be used to check the tube.

**THIRD:** Select the current range that the tube is to be checked at using the information under "SETTING UP THE MIGHTY MITE FOR NEW TUBES", the B LOAD switch section. For our example, the A position would be used as the 6JE6 draws a very heavy plate current under normal use.

FOURTH: Select any pins that must be isolated for a proper test. In this example, we have the control grid on pins 2 and 6 and the screen grid on pins 1 and 7. The "C" switch can isolate only one pin, so we will isolate the extra control grid connection in the tube. The two screen connections will cause the shorts light to glow and therefore a normal shorts indication will exist under the tube settings. Isolate pin 2 by setting the "C" switch to position 2.

FIFTH: Select the control grid pin with the "D" SETUP switch. In this case, since we isolated pin 2, we must pick up pin 6 which is position F on the "D" switch. When we rotate the "D" switch for the shorts test, the short light will glow on pins 1 and 7 or positions A and F of the switch and should be considered normal. Any other indication on this tube would indicate an internal short.

## MAINTENANCE

### DISASSEMBLY INSTRUCTIONS

To remove the Mighty Mite from its case for adjustment of the internal calibration control or for any repairs that may be necessary:

1. Remove the two screws at the top of the front panel.
2. Remove the two screws on the back of the case near the bottom of the unit.

The front panel should now be lifted from the case, exposing the internal circuits of the Mighty Mite for calibration or trouble shooting. To reassemble the Mighty Mite, simply reverse the procedure.

### CALIBRATION

The Mighty Mite should seldom change its calibration through its normal life. With the calibration module described below, you will not only be able to recalibrate the Mighty Mite, but periodically check its calibration and insure yourself of top performance. The module is constructed from an octal plug or an old octal tube base and is inserted into socket number one on the Mighty Mite. Figure 2 shows the schematic of the test module.

- CR1 = Silicon Diode, 100PIV @ .5AMP  
 R1 = 100 Meg (4-22 MEG and 1-12 MEG in series)  
 R2 = 270K  
 R3 = 1K, 1%

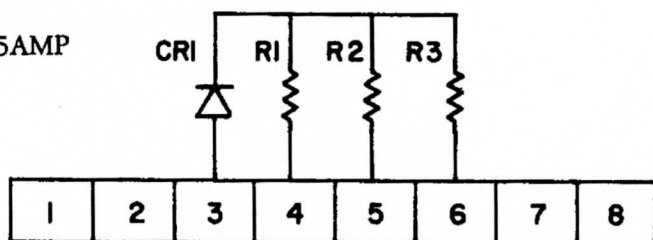

OLD TUBE BASE OR OCTAL PLUG

Figure 2. Cal Module Schematic

There are two calibration controls on the printed circuit board in the Mighty Mite. See Figure 3 for their location. The grid leakage must be set first and then the emission control. The grid leakage control is in series with the meter and will affect both emission and grid leakage calibration. Using the test module described above, plug it into socket number one and set the four front panel controls with the following settings.

	A	B	C	D	SKT
Grid Leakage Calibration	1	D	6	D	1

Depress the SHORTS button and set the meter to zero with the METER ZERO control. Depress the GRID LEAKAGE button and adjust R11, the Grid Leakage cal control until the meter reads on the line between ? and BAD. Depress the SHORTS button and recheck the meter zero. To check and calibrate the emission control, use the following settings:

	A	B	C	D	SKT
Emission Calibration	1	D	6	C	1

With the SHORTS button depressed, check the meter zero. Depress the EMISSION BUTTON and adjust R17, the Emission Cal control until the meter reads ~~40~~ on the emission scale of the meter.



To check the shorts indicating circuit of the Mighty Mite, depress the SHORTS button and rotate the "D" switch through all its positions. Normal shorts should occur on positions E and F.

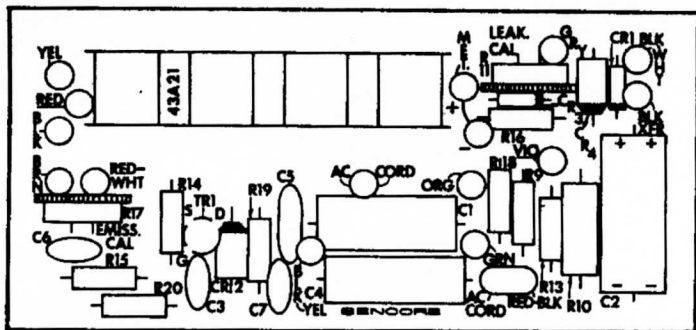

Figure 3. P.C. Board layout

### CIRCUIT DESCRIPTION OF THE MIGHTY MITE VI

The new Mighty Mite VI represents a unique breakthrough in tube checkers, being the first completely solid state tube checker. The new Mighty Mite uses the new FET or Field Effect transistor in place of the usual tube giving instant on action for faster and more accurate tube testing. Now, there is no need for the tube in the tester to warm up and stabilize before checking can begin and the change in calibration that goes along with the aging tube are also gone with the new solid state Mighty Mite.

The basic circuit of the Mighty Mite is a balanced bridge circuit meter amplifier consisting of FET TR1 and diode CR4. The zener diode represents a constant current source and takes the place of the second FET needed for the bridge circuit. The METER ZERO control on the front panel is just like the zero control of a VTVM and balances the circuit so with no signal input, the meter reads zero. When a voltage is impressed on the gate of the FET TR1, the bridge is unbalanced and the meter will read in proportion to the applied signal.

The cathode emission test puts an AC voltage between the control grid of the tube under test and the cathode with a load resistor in series to develop a pulsating DC voltage across. The B LOAD switch selects the different size load resistors and applied voltage so that a full range of current is available from less than .5 mA to 120 mA. The tube under test rectifies the applied AC voltage and develops across the load resistors R1 through R7. The pulsating DC voltage is coupled through the filter network of R17 and C6 to smooth it to a pure DC voltage. This voltage is applied to the gate of TR1 through an additional isolation and filtering network of R14, R15, R20 and C3. The resultant DC voltage upsets the balance of the circuit causing the meter to read upscale in proportion to the emission quality of the tube.

In the grid leakage test, the control grid of the tube under test is made negative to all other elements in the tube by connecting the grid to ground through the 30 megohm gate resistor consisting of R15 and R20, and applying a positive 8 volts to all other elements in the tube. If the tube has any grid leakage or contamination causing the tube grid to emit electrons, the flow of electrons will be through the gate resistor. Any current flow through the resistor will cause a voltage drop across the resistor causing an unbalance in the bridge circuit and the meter to read in proportion to the amount of grid current in the tube under test. A leakage of 100 megohms or less will cause the meter to read into the BAD area. A leakage of 100 to 200 megohms will cause a meter reading in the questionable area and a leakage of 200 megohms or more will read in the GOOD area on the meter. A leakage of 100 megohms represents a grid current in the tube under test of .5 microamps.

The shorts test uses the Sencore Stethoscopic approach where each and every element in the tube is checked against all other elements. A capacitor voltage divider of C1 and C4 is placed across the upper winding of the primary of the filament transformer. The AC voltage at this point is 75 volts and the capacitor C1 drops this to approximately 34 volts RMS that is applied across the elements of the tube. This voltage is below the maximum that should be applied to nuvistors and frame grid tubes to prevent arc over and breakdown in these tubes. C5, a .1 condenser is in series with the shorts test to prevent any DC action of the tube from lighting the shorts light. A true short will cause both elements of the neon bulb to light. If the short is 300,000 ohms or less, the shorts light will glow, but if the short is higher in resistance, the shorts light may only flicker.

The power supply for the FET and the leakage tests consists of diode CR1 and filter condenser C2. The necessary AC voltage is taken from the 22 volt tap on the primary of the filament transformer T1. Zener diode CR2 and resistor R10 regulate the supply voltage to 8 volts so that the voltage remains constant regardless of the line voltage applied to the unit.

#### TROUBLE CHART FOR THE MIGHTY MITE VI

SYMPTOM	PROBABLE CAUSE	CORRECTIVE MEASURE
No meter indication on any position of push button Function switch.	CR1, CR2, TR1, CR3	Check diodes and power supply voltage. Check FET with FET tester and check meter for open with ohm meter.
Grid leakage measures OK, but no emission readings.	S1, T1, Grid leakage push button contacts.	Check resistors on B load switch with ohm meter. Check transformer for opens and Grid leakage switch for open contacts.
Short indicator glows on one anode when checking for shorts.	Shorted or leaky C5	Check C5 for shorted or leaky condition and replace.
Bad tubes indicate very good or full scale.	Open load resistor R1 to R7 or open contacts on emission push button.	Check R1 to R7 for opens with ohm meter. Check contacts on push switch.
Shorts light will not glow, even with a direct short.	Open C5, open contacts on SHORTS push button switch.	Check C5 for open and replace. Check contacts on switch.
Emission OK, but Grid leakage readings not right or absent.	Open contacts on Grid leakage push button switch. Leakage CAL off.	Check contacts on switch. Check and reset Leakage CAL pot.

## MIGHTY MITE VI PARTS LIST

SCHEMATIC NUMBER	PART NO.	DESCRIPTION	PRICE
R1	14G129	300 OHM 10W Taped Resistor	\$ .95
R11	15G61	5K 30% PC Vert Mt CAL POT	.75
R12	15S6	200 OHM 30% Carbon Control	1.50
R15	14G334	30 MEG 1/2W 10% Resistor	.25
CR1	16510	400 VPIV @.5 AMP Silicon Diode	1.50
CR2	50G8	8.2 V 1 Watt Zener Diode	1.95
CR3	19G16	IN816 Stabistor Diode	.75
CR4	50G10	2.2V 20 mA Zener Diode	1.95
TR1	19G35	2N5457 FET (Selected)	1.25
C1	24G81	.0062 MFG 5% 50UV	.25
C2	24G206	50 MFD 35V Lytic	.75
C4	24G179	.0056 MFD 33V Poly	.25
S1	25S42A	2P9P Rotary Switch	3.25
S2	25S22A	1P12P Rotary Switch	2.00
S3	25S41A	11P12P Rotary Switch	5.95
S4	25S43B	2P11P Rotary Switch	3.25
S5	25B130	2P4 Section Push Button	4.95
T1	28B10	Filament Transformer	9.95
#11	26G54	10 Pin Special Socket	.50
#12	26G56	9 Pin Magnoval	.50
	23B34	0-1 MA Meter	20.00
	36G2	Grid Cap and Lead	
	SC8B20	Control Escutcheon Case Complete	

(PRICES SUBJECT TO CHANGE WITHOUT NOTICE)

